

## Yuasa Ultra Extended Life Series VRLA Battery, 20 Years Design Life

Since 1984, the Yuasa UXL series battery has established a reputation as a very reliable power source. These batteries are designed to meet the growing request for longer life and higher reliability. Constructed with special electrolyte separators, the Yuasa UXL battery is guaranteed to have no 'free acid'. This feature allows the battery to be mounted either vertically or horizontally.

- 20 Year Design Life
- Non-Spillable Battery (No Free Acid)
- Gas Pressure Venting System
- No Equalising Charge Required
- UXL GEN2 has been enhanced with an Extended Design Life and for Higher Temperatures.

### General Performance

Battery	UXL550-2FR-G2	
Application	Floating	
Design Life	20 Years @ 25 °C 10 Years @ 35 °C	
Nominal Capacity	500 Ah	
Actual Capacity at 25 °C	1 hour rate to 1.70 V	303 Ah
	3 hour rate to 1.70 V	423 Ah
	10 hour rate to 1.85 V	472 Ah
	10 hour rate to 1.80 V	500 Ah

### Electrolyte

Full charge density at 25 °C	1.260	
Density Range	1.250-1.270	
Gelled/Absorbed	Absorbed	
Mounting Orientation	Vertical / Horizontal	

### Plates

#### Positive Plates:

Number/cell	20	
Typ	Flat Pasted	
Material of grid	Calcium Lead Tin	
Thickness	4.2 mm	

#### Negative Plates:

Number/cell	21	
Type	Flat Pasted	
Material of grid	Calcium Lead Tin	
Thickness	2.4 mm	

\* Contact Century Yuasa for information specific to your application

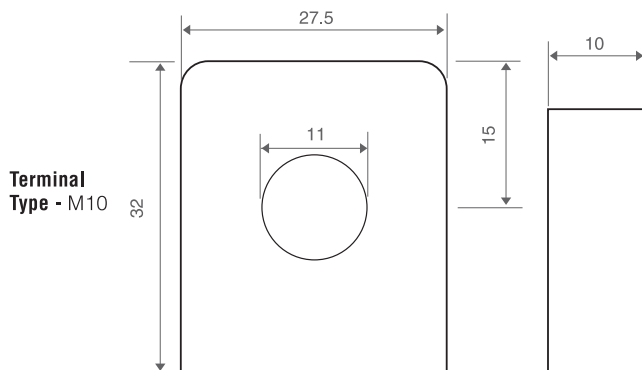

**Terminal Cap Drawing**

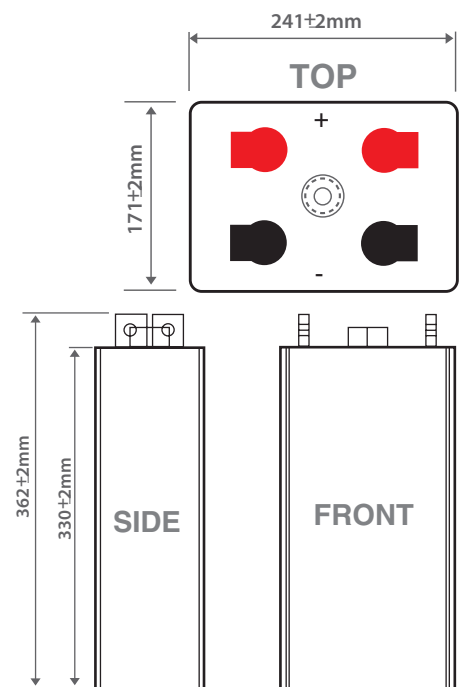

**UXL550-2 GEN2 Battery Drawing**

All reasonable care has been taken to ensure that the data presented in this document is accurate for the purpose for which it is presented. CenturyYuasa reserves the right to make changes to its products and information contained in this document without notice, and shall not be held liable for any loss or damage claimed to have arisen as a result of the use of this brochure.



Yuasa Ultra Extended Life Series VRLA Battery, 20 Years Design Life

## Physical Properties

Separators	
Type	Glass Mat
Is glass fibre included?	Yes
Thickness	3.0 mm
Container & Cover Materials	
Lid Material, Colour	Acrylonitrile Butadiene Styrene ABS/Grey
Container Material, Colour	Acrylonitrile Butadiene Styrene ABS/Grey
Flame Retardant	Yes - UL94V0
Safety Vent Operational Pressure	20kPA
Dimensions	
Width	171mm + 2
Depth	241mm + 2
Height	330mm + 2
Overall Height	362mm + 2
Battery Weight (kg)	
Total Weight (wet)	35.9 kg

## Electrical Properties

Self Discharge Rate @ 25°C	< 3% per month		
Normal Charge (Amperes)	50A		
Max. Charge (Amperes)	50A		
Max. Sustained Current without damage (discharging)	2500A~5 sec		
Internal Resistance (mOHMS)	0.3 mΩ		
Volts End of Charge	2.23 Vpc		
	20°C	25°C	30°C
Float Voltage (Vpc)	2.25 Vpc	2.23 Vpc	2.22 Vpc
Float Current (mA)	~500 mA	~500 mA	~500 mA
Initial Short circuit current (A)	~7400A		
Efficiency at 10 hour rate (%)			
Ampere-Hour	> 90%		
Watt-Hour	> 80%		

## Torque Setting

Terminal Torque Setting	14.7 - 19.6 N.m.
-------------------------	------------------

## Compliant Standard

Manufacturing Standard	JIS C 8704-2-2:2019; JIS C 8704-2-1:2019
Test Standards	AS 60896-21; AS 60896-22

## Charging Characteristics

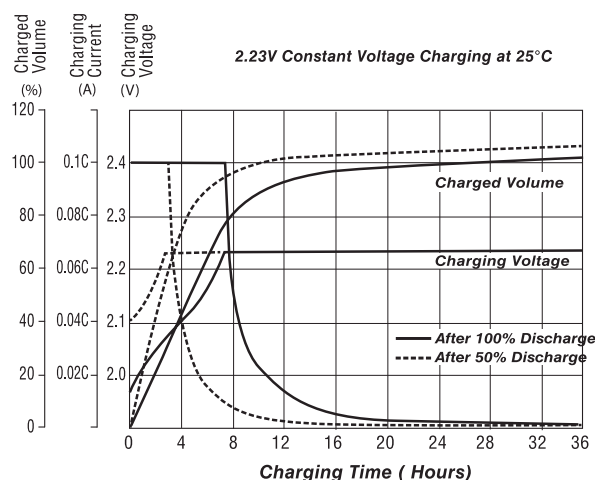

## Discharge Characteristics Curves at 25°C

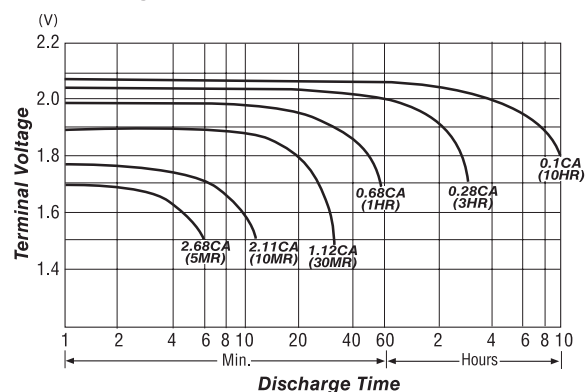

View GHS7 compliant SDS by visiting [www.intelepower.com.au/resources/msds](http://www.intelepower.com.au/resources/msds)

An affiliated business of the GS Yuasa Corporation, Century Yuasa has a 100-year history of supplying a range of stored energy solutions to the Australian market. An established network of sales and distributions offices throughout Australia and New Zealand has seen the business gain the trust and respect from its customers by focusing on quality products and exceptional customer service. CenturyYuasa is Australia's enduring manufacturer of stored energy products.