



## Yuasa UXH Series VRLA Battery, 10 Years Design Life

Yuasa UXH batteries are constructed to yield even greater capacity than comparable batteries. The UXH uses AGM technology which ensures that there is no 'free acid' in the battery. This allows the battery to be mounted either vertically or horizontally. An additional feature of this product is Yuasa's heavy duty lead calcium-tin alloy, providing the UXH battery the ability to remain in float service for 10 years.

- 10 Year Design Life
- High Energy Density
- Gas Pressure Venting System
- No Equalising Charge Required

### General Performance

Battery	UXH75-6	
Application	Floating	
Design Life	10 Years	
Nominal Capacity	75Ah	
Actual Capacity at 25°C	1 hour rate to 1.70 V	43.5Ah
	3 hour rate to 1.70 V	58.5Ah
	10 hour rate to 1.80 V	69Ah

### Electrolyte

Full charge density at 20°C	1.300
Density Range	1.290-1.310
Gelled/Absorbed	Absorbed
Mounting Orientation	Vertical / Horizontal

### Plates

#### Positive Plates:

Number/cell	6
Typ	Flat Pasted
Material of grid	Lead-Calcium-Tin Alloy
Thickness	4.0 mm

#### Negative Plates:

Number/cell	7
Type	Flat Pasted
Material of grid	Lead-Calcium-Tin Alloy
Thickness	2.3 mm

\* Contact Century Yuasa for information specific to your application

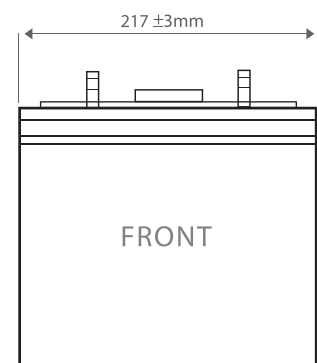
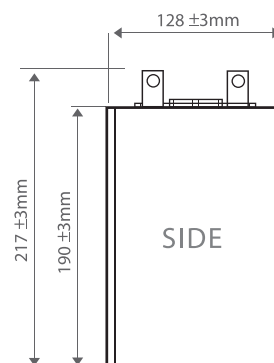
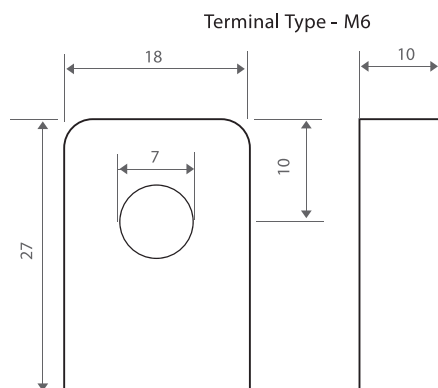
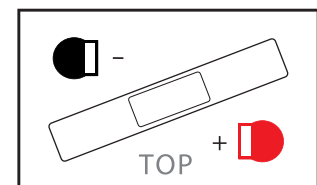

All reasonable care has been taken to ensure that the data presented in this document is accurate for the purpose for which it is presented. CenturyYuasa reserves the right to make changes to its products and information contained in this document without notice, and shall not be held liable for any loss or damage claimed to have arisen as a result of the use of this brochure.



## Yuasa UXH Series VRLA Battery, 10 Years Design Life

Physical Properties	
<b>Separators</b>	
Type	Glass Mat
Is glass fibre included?	Yes
Thickness	1.5 mm
<b>Container &amp; Cover Materials</b>	
Lid Material, Colour	Acrylonitrile Butadiene Styrene ABS/Dark Grey
Container Material, Colour	Acrylonitrile Butadiene Styrene ABS/Dark Grey
Flame Retardant	No
Safety Vent Operational Pressure	20kPA
Flame Arrestor Filter Fitted	Yes
<b>Dimensions</b>	
Width	217 mm ± 3
Depth	128 mm ± 3
Height	190 mm ± 3
Overall Height	217 mm ± 3
<b>Battery Weight (kg)</b>	
Total Weight (wet)	16 kg

Electrical Properties			
Self Discharge Rate @ 25°C	< 3% per month		
Normal Charge (Amperes)	7.5A		
Max. Charge (Amperes)	15A		
Max. Sustained Current without damage (discharging)	345A (5 sec)		
Internal Resistance (mOHMS)	2.2mΩ		
Volts End of Charge	2.275 Vpc		
	20°C	25°C	30°C
Float Voltage (Vpc)	2.290 Vpc	2.275 Vpc	2.260 Vpc
Float Current (mA)	~75mA	~75mA	~75mA
Initial Short circuit current (A)	~3000A		
Efficiency at 10 hour rate (%)			
Ampere-Hour	> 90%		
Watt-Hour	> 78%		

Torque Setting	
Terminal Torque Setting	3.9 - 5.4 N.m.

Compliant Standard	
Manufacturing Standard	JIS C8704-2: 1999

### Discharge Characteristics

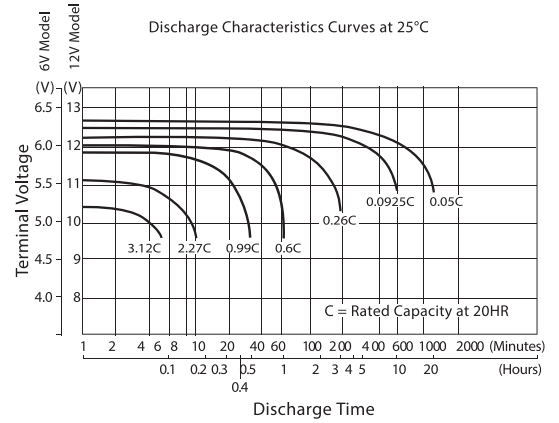

### Charging Characteristics

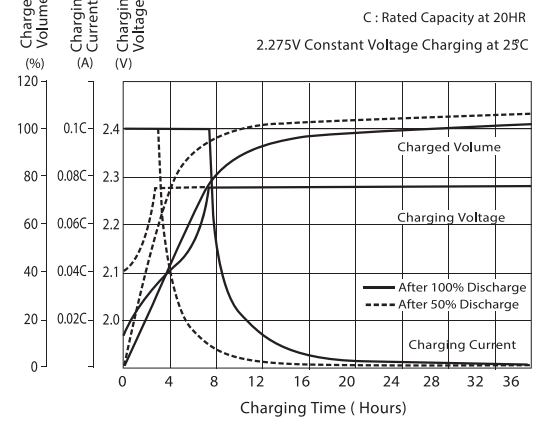

View Yuasa UXH Range by visiting [intelepower.com.au/products/yuasa-uxh-range/](http://intelepower.com.au/products/yuasa-uxh-range/)

An affiliated business of the GS Yuasa Corporation, Century Yuasa has an 100-year history of supplying a range of stored energy solutions to the Australian market. An established network of sales and distributions offices throughout Australia and New Zealand has seen the business gain the trust and respect from its customers by focusing on quality products and exceptional customer service. CenturyYuasa is Australia's enduring manufacturer of stored energy products.